

## Key Points on Chapter 23: Faraday's Law and Inductance

- Emf is \_\_\_\_\_ due to electrostatic charges.
- Emf can be produced by \_\_\_\_\_ a loop of wire in a magnetic field.
- The emf is minus the rate of \_\_\_\_\_ of magnetic flux through the loop.
- A changing magnetic field produces an \_\_\_\_\_ field.
- Lenz' law says that an induced current would \_\_\_\_\_ the change in flux.
- The power dissipation equals the rate of \_\_\_\_\_.
- \_\_\_\_\_ inductance is purely a geometrical quantity.
- The self-induced flux through a loop is proportional to the \_\_\_\_\_.
- The proportionality constant is called the \_\_\_\_\_.
- The unit of inductance is the \_\_\_\_\_.
- \_\_\_\_\_ is stored in magnetic fields.
- A \_\_\_\_\_ raises or lowers the voltage without changing the power supplied.
- The time constant in an RL circuit is \_\_\_\_\_.
- \_\_\_\_\_ inductances in series to get the equivalent inductance.
- Add \_\_\_\_\_ inductances in parallel to get the equivalent inverse inductance.

## Lectures on Chapter 23: Faraday's Law and Inductance

### EMF

It takes work to move charges around a circuit. The emf is the amount of work done per unit charge

$$\mathcal{E} = \frac{dW}{dq}$$

Recall that work is defined as

$$W = \int \vec{F} \cdot d\vec{s} \quad \begin{array}{l} \vec{F} = \text{force on object} \\ d\vec{s} = \text{path element} \end{array}$$

The work done in dragging a charge around a circuit is

$$W = \oint \vec{F} \cdot d\vec{s} \quad \text{integrate around a closed loop}$$

Let  $\vec{f}$  be the force per unit charge

$$\vec{f} = \frac{d\vec{F}}{dq}$$

Then the work per unit charge done in dragging a charge around a circuit is the emf  $\mathcal{E}$ :

$$\mathcal{E} = \frac{dW}{dq} = \oint \frac{d\vec{F}}{dq} \cdot d\vec{s} = \oint \vec{f} \cdot d\vec{s}$$

Emf is \_\_\_\_\_ due to electrostatic charges.

We might be tempted to say that  $\vec{f} = \frac{\vec{F}}{q} = \vec{E}$  where  $\vec{E}$  is the electrostatic electric field set up by charges. But you can't get a steady current flow by putting some charges near a wire. If you put a wire in an external electrostatic  $\vec{E}$  field produced by stationary charges, the charges in the conducting wire would quickly rearrange themselves to make the wire an equipotential. But you need a voltage drop to get current to flow.

Another way to see that  $\vec{f} \neq \vec{E}_{\text{electrostatic}}$  is to note that

$$\oint \vec{E}_{\text{electrostatic}} \cdot d\vec{s} = 0$$

$\implies$  Emf due to  $\vec{E}_{\text{electrostatic}}$  is zero.

Recall our definition of electric potential

$$\Delta V = V_b - V_a = - \int_a^b \vec{E}_{\text{electrostatic}} \cdot d\vec{s}$$

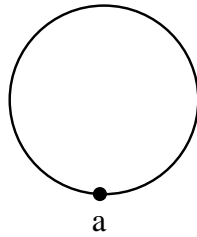

If we start at point **a**, go around a loop, and end at point **a**, then

$$\Delta V = - \int_a^a \vec{E} \cdot d\vec{s} = V_a - V_a = 0$$

So in our expression  $\mathcal{E} = \oint \vec{f} \cdot d\vec{s}$ ,  $\vec{f}$  is a force per unit charge that is *not* due to electrostatic charges.  $\vec{f}$  is a force that keeps the charges moving.  $\vec{E}_{electrostatic}$  doesn't do this.  $\vec{f}$  can be the electric field  $\vec{E}$  produced by an ongoing chemical reaction in a battery. Or  $\vec{f}$  can be the force produced by the conveyor belt in a van de Graaff generator.

Emf can be produced by \_\_\_\_\_ a loop of wire in a magnetic field.

One of the most important sources of an emf is caused by the motion of a loop of wire through a magnetic field. This is the principle behind electric generators. In the shaded region, there is a uniform magnetic field  $\vec{B}$ , pointing into the page, and the resistor  $R$  represents whatever it is (maybe a light bulb or a toaster) we're trying to drive a current through.

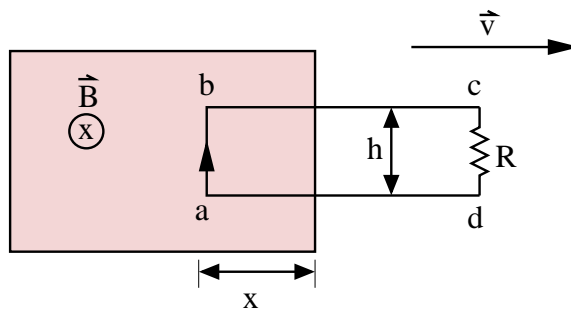

If the loop is pulled to the right with velocity  $\vec{v}$ , the charges in the vertical segment  $ab$  feel a magnetic force  $qvB$  in the direction of the wire. (The other segments feel forces perpendicular to the wire.) The figure below shows the forces if  $I = 0$ .

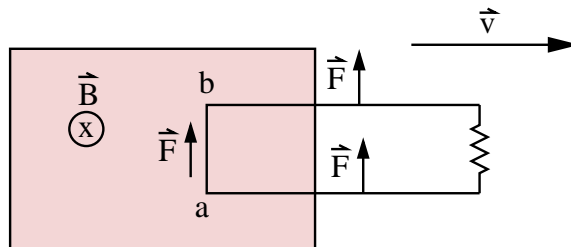

The force  $qvB$  on the charges in the segment  $ab$  drives a current around the loop in the clockwise direction. The force per unit charge is

$$f = \frac{F}{q} = \frac{qvB}{q} = vB$$

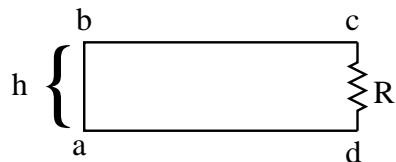

Let  $h$  = height of loop = distance from  $a$  to  $b$ . Then the emf is

$$\mathcal{E} = \oint_C \vec{f} \cdot d\vec{s} = \int_a^b \vec{f} \cdot d\vec{s} + \int_b^c \vec{f} \cdot d\vec{s} + \int_c^d \vec{f} \cdot d\vec{s} + \int_d^a \vec{f} \cdot d\vec{s} \quad (1)$$

The integrals from  $b \rightarrow c$  and from  $d \rightarrow a$  are 0 because  $\vec{f} \perp d\vec{s}$ . The integral from  $c \rightarrow d$  is zero because it is outside the  $\vec{B}$  field. So

$$\begin{aligned} \mathcal{E} &= \int_a^b \vec{f} \cdot d\vec{s} \\ &= vBh \end{aligned}$$

The emf is minus the rate of \_\_\_\_\_ of magnetic flux through the loop.

We can relate the emf to the magnetic flux  $\Phi_B$  through the loop.

$$\Phi_B = \int_S \vec{B} \cdot d\vec{a}.$$

This is like the electric flux  $\Phi_E = \int \vec{E} \cdot d\vec{a}$  that we defined for Gauss' law. However, the surface  $S$  we are integrating over for  $\Phi_B$  is not closed.  $d\vec{a}$  is an element of the surface pointing in the direction normal to the element  $da$ . Which normal you pick is arbitrary at the moment. But it will turn out that  $d\vec{a}$  points according to the right hand rule for the curve  $C$ .  $\oint_C \vec{f} \cdot d\vec{s}$ . You can think of  $\Phi_B$  as the number of magnetic field lines piercing the surface  $S$ .

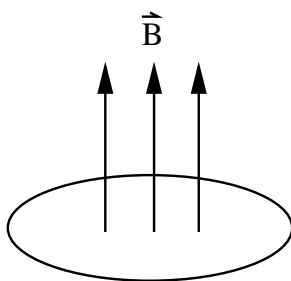

## Units

$$[\Phi_B] = \text{tesla} \cdot \text{meter}^2 = \text{weber} = \text{Wb}$$

$$1 \text{ weber} = 1 \text{ Wb} = 1 \text{ T} \cdot \text{m}^2$$

Let's calculate the flux through our loop.

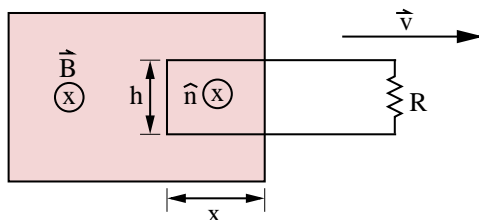

Let's choose the normal  $\hat{n}$  to the loop to point into the page. When we evaluated  $\oint_C \vec{f} \cdot d\vec{s}$ , we went around the loop in a specific direction. If the fingers of our right hand curl in this direction, our thumb points in the direction of the normal  $\hat{n}$ . So  $\hat{n}$  points in the same direction as  $\vec{B}$ . So  $d\vec{a}$  points in the same direction as  $\vec{B}$ . Then

$$\Phi_B = \int \vec{B} \cdot d\vec{a} = B \cdot \text{area} = Bhx$$

As the loop moves, the flux decreases:

$$\frac{d\Phi}{dt} = Bh \frac{dx}{dt} = -Bhv \quad \left( \frac{dx}{dt} = -v \right)$$

We need the minus sign to indicate that the flux is decreasing. Compare this with our expression for the emf:

$$\mathcal{E} = Bhv \tag{2}$$

$$\mathcal{E} = -\frac{d\Phi_B}{dt} \tag{3}$$

This is called **Faraday's Law**. Thus the emf generated is minus the rate of change of flux through the loop. We derived this relation for a special case but it is true in general. This is true for a loop of arbitrary shape moving in any direction through a magnetic field. If we have a coil with  $N$  turns of wire that experiences changing flux, then an induced emf appears in every turn and we add these emf's:

$$\mathcal{E} = -N \frac{d\Phi_B}{dt}$$

Faraday's law is the principle behind electric generators. Emf that can drive electric currents are generated by changing the flux through coils of wire.

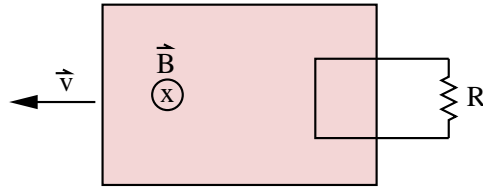

A changing magnetic field produces an \_\_\_\_\_ field.

So far we have been considering a static  $\vec{B}$  field and a moving loop. What happens if we hold the loop stationary and move the source of the magnetic field with a velocity opposite to that of the loop when it was moved? Faraday found that exactly the same emf is produced. What matters is the *relative* motion of the loop and  $\vec{B}$ . How did Faraday interpret this? What makes the charges move?

$$\vec{F}_{mag} = q\vec{v} \times \vec{B} = 0$$

because the velocity  $\vec{v}$  of the charge is zero (the loop is stationary). To get the electrons to flow, we need an electric field. This must mean that **a time varying  $\vec{B}$  field produces an  $\vec{E}$  field!** To see this mathematically, note that

$$\mathcal{E} = \oint_C \vec{E} \cdot d\vec{s} \tag{4}$$

and

$$\mathcal{E} = -\frac{d\Phi_B}{dt} = -\frac{d}{dt} \int_S \vec{B} \cdot d\vec{a} \tag{5}$$

$$\implies \oint_C \vec{E} \cdot d\vec{s} = -\frac{d}{dt} \int_S \vec{B} \cdot d\vec{a}$$

Here the closed loop  $C$  is spanned by the surface  $S$ .

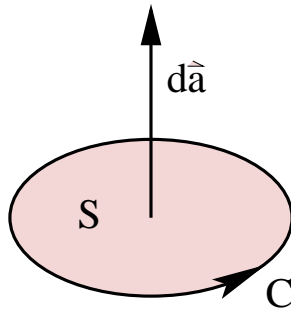

The direction of  $d\vec{s}$  around  $C$  is related to the direction of  $d\vec{a}$  by the right hand rule. Notice that the changing magnetic field on the right hand side of the equation produces the  $\vec{E}$  field on the left hand side.

Faraday's law tells us that we can generate an  $\vec{E}$  field simply by changing the magnetic flux. It doesn't matter how we change the flux. We can move the loop, or we can move

the magnet, or we can just increase or decrease the magnetic field while the loop and the magnet are stationary. Actually, you don't need to have a wire to induce an  $\vec{E}$  field. In empty space, a changing  $\vec{B}$  field will induce an  $\vec{E}$  field. Applications: generators, microphones, stereo speakers.

### Lenz's Law

Lenz' law says that an induced current would \_\_\_\_\_  
the change in flux.

Lenz's law gives us an easy way to keep track of the direction of current flow induced by changing flux:

“The emf induced is in such a direction, that if a current flows, the magnetic field produced by the induced current opposes the change in flux that produced the emf.”

This is the meaning of the minus sign in Faraday's law. Analogy: Let's suppose money going into your bank account is like magnetic flux going through a loop of wire. Suppose you earn \$1000/month which you put into your bank account. Now if your boss says that you're going to get a pay cut and that you'll be earning \$500/month, you would oppose this change. There's still money going into your bank account, but it's less. There's still flux going through the loop, but it's less. So you would try to supplement your earnings with an extra job. The loop has an induced current flowing in it that supplements the external reduced flux.

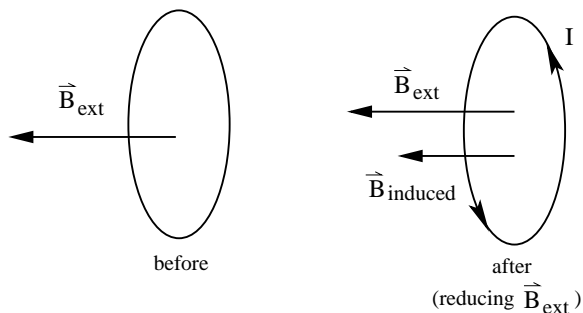

You probably wouldn't oppose a salary raise so let me draw another analogy. Let's suppose you are in a boat in the middle of a lake. The boat springs a leak and water starts to pour in. This is like increasing flux through the loop. You would oppose this change by trying to reduce the amount of water pouring in; i.e., by bailing water out of the boat. Similarly, the induced current in the loop produces flux opposite to the increasing external flux.

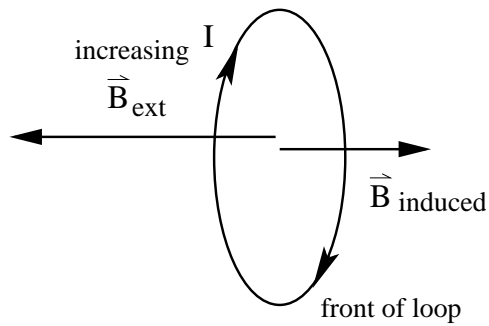

The basic message of Lenz's law: Oppose change.

**Example: Jumping Ring**

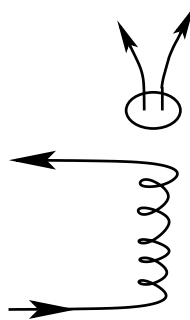

If you place a metal ring on top of a solenoid, then turn on the current in the solenoid, the ring will jump off. (It helps to have an iron core in the solenoid to increase the  $\vec{B}$  field.) Why does the ring jump off? When you turn on the current, the flux through the ring suddenly increases from zero to non-zero value ( $\frac{d\Phi_B}{dt} \neq 0$ ). This induces an emf in the ring that drives a current in the ring. According to Lenz's law, the induced current in the ring will produce a  $\vec{B}$  field in the opposite direction to that of the solenoid. So like 2 bar magnets  $\boxed{S \ N} \ \boxed{N \ S}$ , the ring and solenoid repel and the ring flies off.

**Example**

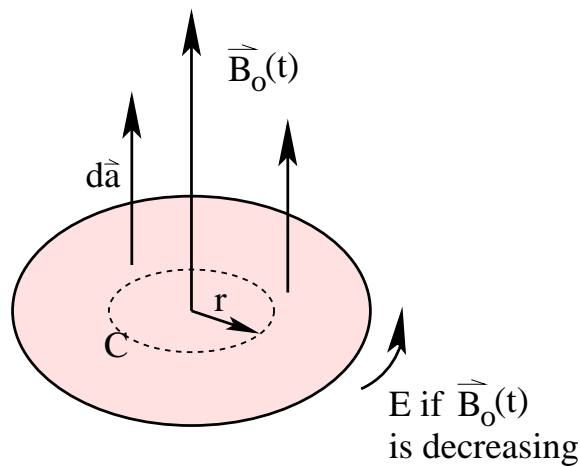



A uniform magnetic field  $\vec{B}_0(t)$ , pointing straight up, fills the shaded circular region. If it changes with time, what is the induced electric field  $\vec{E}$ ?

**Solution:** Draw a loop  $C$  of radius  $r$  and apply Faraday's law.

$$\oint_C \vec{E} \cdot d\vec{s} = -\frac{d\Phi_B}{dt} = -\frac{d}{dt} \int_S \vec{B} \cdot d\vec{a} \quad (6)$$

where  $S$  = surface spanned by loop  $C$ . Let's evaluate the left hand and right hand sides of this equation.

$$\begin{aligned} \oint_C \vec{E} \cdot d\vec{s} &= E \cdot 2\pi r \\ -\frac{d\Phi_B}{dt} &= -\frac{d}{dt} \int_S \vec{B} \cdot d\vec{a} = -\frac{d}{dt} (\pi r^2 B_0(t)) = -\pi r^2 \frac{dB_0(t)}{dt} \\ \oint_C \vec{E} \cdot d\vec{s} &= -\frac{d\Phi_B}{dt} \\ E \cdot 2\pi r &= -\pi r^2 \frac{dB_0(t)}{dt} \\ \vec{E} &= -\frac{r}{2} \frac{dB_0}{dt} \hat{\phi} \quad (\hat{\phi} \text{ means } \vec{E} \text{ is circumferential.}) \end{aligned}$$

Once you figure out which way  $\vec{B}_{ind}$  points, use the right hand rule to get the direction of  $\vec{E}$ .

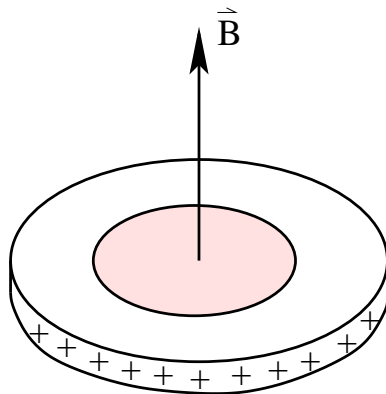

If the circular region is mounted on a wheel that's free to rotate and there is a line of uniform charge mounted on the rim of the wheel, then the wheel will start to spin as the  $\vec{B}$  field decreases because the induced  $\vec{E}$  field will push the charges and hence the wheel. Where does the angular momentum come from? It can't come from nowhere because angular momentum is conserved. It turns out that the angular momentum comes from the  $\vec{E}$  and  $\vec{B}$  fields.  $\vec{E}$  and  $\vec{B}$  have energy, momentum, and angular momentum. The angular momentum density is  $\mathcal{L}_{EB} = \epsilon_0 \vec{r} \times (\vec{E} \times \vec{B})$ .

### Power Dissipation

The power dissipation equals the rate of \_\_\_\_\_.

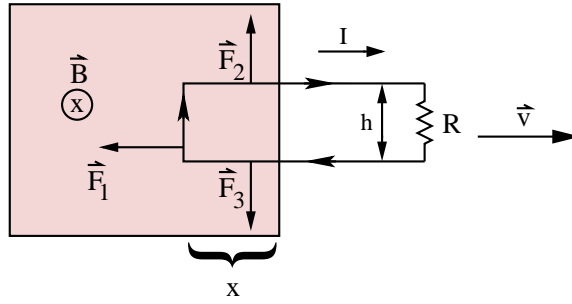

Let's revisit the loop of wire that we were pulling out of the magnetic field. We saw that the emf induces a current  $I$  that tries to replenish the flux. The current in the loop feels a force

$$\vec{F} = I\vec{\ell} \times \vec{B}$$

The forces are shown in the figure. Since  $\vec{F}_2 = -\vec{F}_3$ , they cancel out. Only  $\vec{F}_1$  survives.  $\vec{F}_1$  opposes the force we use to pull the loop out of the  $\vec{B}$  field. Note that  $|\vec{\ell}| = h$  and  $\vec{\ell} \perp \vec{B}$ . So

$$\vec{F}_1 = IlB \sin 90^\circ = IlB = Ihb \quad (7)$$

We can find  $I$  by noting that  $I = \mathcal{E}/R$  and

$$\mathcal{E} = Bhv \quad \Longrightarrow \quad I = \frac{\mathcal{E}}{R} = \frac{Bhv}{R}$$

You do work on the loop because  $\vec{F}_1$  opposes you. You must apply at least a force  $\vec{F}$  that is equal and opposite to  $\vec{F}_1$  to keep the loop moving.  $\vec{F}_1$  is like friction force. (Do you need to apply more than  $\vec{F}_1$  to keep the loop moving? No, if  $\vec{v} = \text{constant}$ ,  $\vec{a} = d\vec{v}/dt = 0 \implies \vec{F}_{extra} = 0$ .)

$$|\vec{F}| = |\vec{F}_1| = IhB = \frac{Bhv}{R} \cdot hb = \frac{B^2h^2v}{R} \quad (8)$$

The rate at which you do work is the power you expend:

$$P = Fv = \frac{B^2h^2v}{R} \cdot v = \frac{B^2h^2v^2}{R} \quad (9)$$

The rate at which you do work is turned into power dissipated in the resistor  $R$ :

$$\begin{aligned} P &= I^2R \\ I &= \frac{Bhv}{R} \\ \implies P &= I^2R = \left(\frac{Bhv}{R}\right)^2 R = \frac{B^2h^2v^2}{R} \end{aligned}$$

Notice that  $I^2R = Fv$ , i.e., the rate of dissipating power in the resistor equals the rate at which you do work.

### Inductance

Suppose we have 2 loops of wire with one above the other.

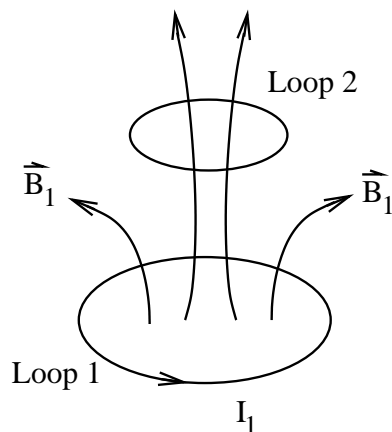

If we run a current  $I_1$  through loop 1, it will produce a magnetic field  $\vec{B}_1$ . Let  $\Phi_2$  be the flux of  $\vec{B}_1$  passing through loop 2:

$$\Phi_2 = \oint_2 \vec{B}_1 \cdot d\vec{a}_2$$

From the Biot-Savart law

$$\vec{B}_1 = \frac{\mu_0}{4\pi} I_1 \oint \frac{d\vec{s} \times \vec{r}}{r^3} \quad (10)$$

we see that  $\vec{B}_1$  is proportional to  $I_1$  which implies that  $\Phi_2$  is proportional to  $I_1$ :

$$\Phi_2 = M_{21} I_1 \quad (11)$$

where the constant of proportionality  $M_{21}$  is called the **mutual inductance**.

\_\_\_\_\_ inductance is purely a geometrical quantity.

There are 2 things to note about mutual inductance:

1. This is a purely geometric quantity. It depends on the sizes, shapes, and relative distance of the loops. It does *not* depend on the current  $I_1$ .
2.  $M_{21} = M_{12} = M$ .

This implies that the flux  $\Phi_2$  through 2 produced by a current  $I$  flowing through loop 1 is exactly the same as the flux  $\Phi_1$ , through 1 produced by  $I$  flowing through loop 2:

$$\Phi_2 = M_{21} I = M_{12} I = \Phi_1$$

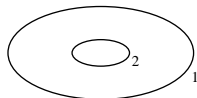

If we vary the current in loop 1,  $\Phi_2$  will vary and this will produce an emf in loop 2:

$$\varepsilon_2 = -\frac{d\Phi_2}{dt} = -M_{21} \frac{dI_1}{dt}$$

So loop 1 can generate a current in loop 2 without touching it.

Note that if the flux is through a coil with N turns, then  $\Phi \rightarrow N\Phi$ .

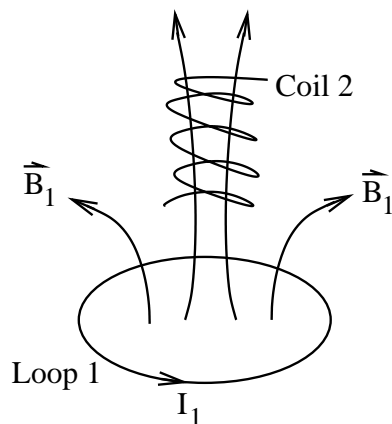

Thus

$$N_2\Phi_2 = M_{21}I_1$$

$$\mathcal{E}_2 = -N_2\frac{d\Phi_2}{dt} = -M_{21}\frac{dI_1}{dt}$$

### Self-Inductance

The self-induced flux through a loop is proportional to the \_\_\_\_\_.

The proportionality constant is called the \_\_\_\_\_.

We don't need two loops to see this effect. If we have only one loop with a current flowing around it, the current produces a  $\vec{B}$  field. This  $\vec{B}$  field produces a flux through the loop.

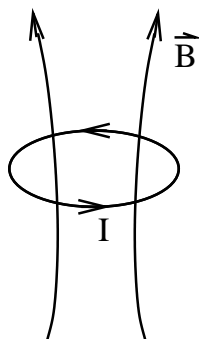

The flux is proportional to the current:

$$\Phi = LI \tag{12}$$

where  $I$  is the current. The constant of proportionality  $L$  is called the **self-inductance** of the loop. As with  $M$ , it depends solely on the geometry (size and shape) of the loop. If the current changes, then there will be a changing flux through the loop which in turn will produce an emf in the loop given by Faraday's law:

$$\begin{aligned}\mathcal{E} &= -\frac{d\Phi}{dt} \\ \mathcal{E} &= -L\frac{dI}{dt}\end{aligned}$$

The minus sign implies that whenever we change the current, the change produces a "back emf" that opposes the change. Thus currents want to stay constant.  $L$  gives the system inertia. It acts like a mass does in a mechanical system.

### Units of Inductance

The unit of inductance is the \_\_\_\_\_.

Inductance is measured in henries (H):

$$\begin{aligned}1 \text{ henry} = 1H &= 1 \frac{\text{volt} \cdot \text{sec}}{\text{Ampere}} \\ [L] &= [\mathcal{E}] \cdot \left[ \frac{dt}{dI} \right]\end{aligned}$$

Note that if we replace a loop with a coil that has  $N$  turns, then  $\Phi \rightarrow N\Phi$ :

$$N\Phi = LI \tag{13}$$

and

$$\mathcal{E} = -N\frac{d\Phi}{dt} = -L\frac{dI}{dt} \implies \mathcal{E} = -L\frac{dI}{dt} \tag{14}$$

as before.

### Recipe to Calculate Inductance $L$

Problem: Given geometry of inductor, find the self-inductance  $L$ .

**Recipe for the Solution:** Use

$$L = \frac{N\Phi}{I} \tag{15}$$

1. Assume current  $I$  flows through the inductor.
2. Calculate  $\vec{B}$  using Ampere's Law or Biot-Savart Law.
3. Calculate flux  $\Phi = \int \vec{B} \cdot d\vec{a}$ .
4. Use  $L = \frac{N\Phi}{I}$  where  $N$  = total number of turns of wire in the inductor

### Inductance of a Solenoid

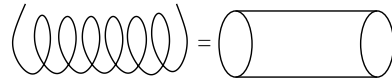

Suppose we have a very long solenoid with cross sectional area  $A$  and  $n$  turns per unit length. What is the self-inductance per unit length  $L/\ell$ ?

**Solution:** Use

$$N\Phi = LI \rightarrow L = \frac{N\Phi}{I} \quad (16)$$

For a length  $\ell$  of the solenoid, there are  $N = n\ell$  turns. Assume a current  $I$  flows through the coil. (This is analogous to assuming a charge  $q$  on a capacitor when we calculate capacitance.) To calculate the flux  $\Phi = \int \vec{B} \cdot d\vec{a}$ , we need  $\vec{B}$ .

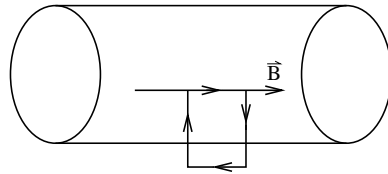

To find  $\vec{B}$ , use Ampere's law:

$$\begin{aligned} \oint \vec{B} \cdot d\vec{s} &= \mu_0 I_{enc} \\ B\ell &= \mu_0 n\ell I \\ B &= \mu_0 nI \\ \Phi &= \int \vec{B} \cdot d\vec{a} = BA = \mu_0 nIA \\ L &= \frac{N\Phi}{I} = \frac{(n\ell)(\mu_0 nIA)}{I} = \mu_0 n^2 \ell A \\ \frac{L}{\ell} &= \mu_0 n^2 A \end{aligned}$$

### Energy Stored in Magnetic Fields

\_\_\_\_\_ is stored in magnetic fields.

In order to get current started in a current loop, we need to do work against the back emf that opposes the increase in current. The work we do gets stored as potential energy. So to find the potential energy, we calculate how much work is done as follows. The rate of doing work (or power going into the inductor) is given by:

$$\frac{dW}{dt} = \frac{dW}{dq} \frac{dq}{dt} \quad (17)$$

Note that  $dq/dt = I$ , the current. To find  $dW/dq$ , note that the back emf  $\mathcal{E}_L = -L(dI/dt)$ . So the work done by the battery per unit charge to overcome the back

emf is  $dW/dq = -\mathcal{E}_L$ . (Recall that  $\mathcal{E} = dW/dq$  is the work lost per unit charge in going through the inductor. The energy gained by the magnetic field is minus this.) Thus

$$\begin{aligned}\frac{dW}{dt} &= \frac{dW}{dq} \frac{dq}{dt} = -\mathcal{E}_L I = \left(L \frac{dI}{dt}\right) I \\ dW &= LI dI\end{aligned}$$

Integrate, starting from  $I = 0$  at  $t = 0$ , to get the total amount of work done by the battery to get to current  $I$ :

$$\begin{aligned}W &= \int dW = \int_{I=0}^I LI dI \\ W &= \frac{1}{2} LI^2\end{aligned}$$

Since this work goes into magnetic potential energy  $U_B$ , we have

$$U_B = W \tag{18}$$

or

$$U_B = \frac{1}{2} LI^2 \tag{19}$$

Once we get the current going, where did all the energy we put into the system go? Answer: the energy is stored in the magnetic field. In fact the energy density is given by

$$u_B = \frac{U_B}{\text{volume}} = \frac{B^2}{2\mu_0}$$

This equation is true in general. However, let's prove it for the special case of an infinite solenoid.

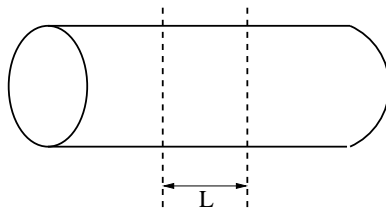

Plug  $U_B = \frac{1}{2} LI^2$  into

$$u_B = \frac{U_B}{\text{volume}} = \frac{1}{2} \frac{LI^2}{\text{volume}} = \frac{1}{2} \frac{LI^2}{A\ell}$$

where  $\ell$  is the length of a section of the solenoid and  $A$  is the cross sectional area of the solenoid. So  $A\ell$  is the volume of that section of solenoid. To get  $u_B$  in terms of  $B$ , note that  $B = \mu_0 In$  in a solenoid.

$$B = \mu_0 In \quad \implies \quad I = \frac{B}{\mu_0 n} \tag{20}$$

So

$$u_B = \frac{1}{2} \frac{LI^2}{A\ell} = \frac{1}{2} \frac{L}{A\ell} \left( \frac{B}{\mu_0 n} \right)^2 \quad (21)$$

To get rid of the self-inductance  $L$ , we recall that

$$\begin{aligned} \frac{L}{\ell} &= \mu_0 n^2 A \\ \Rightarrow u_B &= \frac{1}{2} \frac{1}{A} \frac{L}{\ell} \left( \frac{B}{\mu_0 n} \right)^2 = \frac{1}{2A} (\mu_0 n^2 A) \left( \frac{B^2}{\mu_0^2 n^2} \right) = \frac{B^2}{2\mu_0} \end{aligned}$$

So

$$u_B = \frac{B^2}{2\mu_0} \quad (22)$$

as advertised. This is the magnetic analog of  $u_E = \frac{1}{2}\epsilon_0 E^2$ .

### Transformers

A \_\_\_\_\_ raises or lowers the voltage without changing the power supplied.

Electric power plants send electricity to us over high voltage power lines. The power they supply is  $VI$ . They make the voltage  $V$  large and the current  $I$  small. To see why, note that the transmission lines have a small amount of resistance  $R$ , and the power lost in heating the transmission line is  $I^2R$ . To reduce losses, they make  $I$  small so that  $I^2R$  will be small. They make the voltage  $V$  high so that they can transmit a large amount of power  $VI$ . But we don't want to operate our appliances at 10 kV. We operate our appliances at 110 V. To convert the high voltage of the transmission line into a smaller voltage, a transformer is used.

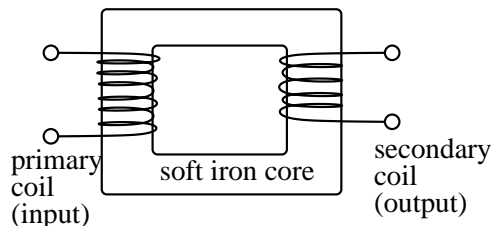

A transformer is a device that either raises or lowers the voltage without changing the power  $VI$  supplied. It works with an AC or alternating current. It consists of 2 solenoidal coils wrapped around a cylinder in such a way that the same amount of flux passes through every turn. Usually the cylinder is an iron core, which has the effect of concentrating the magnetic flux. (I have drawn the coils separated so that you can see them easily. It's a mess if I draw them intertwined.) The primary coil has  $N_p$  turns and the secondary coil has  $N_s$  turns. Let  $\Phi_B$  be the magnetic flux through the iron core. Since there is an AC current, the flux is changing with time. It oscillates and changes direction. Faraday's law tells us that a changing flux induces an emf:

$$\mathcal{E} = -N \frac{d\Phi_B}{dt} \quad (23)$$



The voltage in each coil is equal to the emf induced in that coil. Let  $V_p$  and  $V_s$  be the voltages induced across the primary and secondary coils, respectively. Then

$$V_p = -N_p \frac{d\Phi_B}{dt} \quad V_s = -N_s \frac{d\Phi_B}{dt} \quad (24)$$

The same amount of flux passes through each turn, so the emf  $\mathcal{E}_{turn}$  induced in each turn is

$$\mathcal{E}_{turn} = -\frac{d\Phi_B}{dt} = \frac{V_p}{N_p} = \frac{V_s}{N_s} \quad (25)$$

or

$$V_s = V_p \left( \frac{N_s}{N_p} \right) \quad (26)$$

This is the key to how a transformer works. If  $N_s > N_p$ , then  $V_s > V_p$ . This is called a step-up transformer because it steps the voltage  $V_p$  up to a higher voltage  $V_s$ . If  $N_s < N_p$ , then  $V_s < V_p$ . This is called a step-down transformer because it steps the voltage  $V_p$  down to a lower voltage  $V_s$ .

### RL Circuits

Consider a circuit with a resistor and an inductor in series.

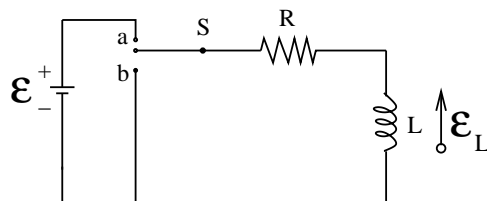

When we close the switch on a, current starts to flow  $\implies \frac{dI}{dt} \neq 0$ . The rise in current produces an induced emf in the inductor that opposes the rise in current:  $\mathcal{E}_L = -LdI/dt$ . As time goes on, the rate of increase of the current becomes less rapid and the magnitude of the self-induced emf,  $\mathcal{E}_L = -LdI/dt$ , decreases because  $dI/dt$  decreases. As  $t \rightarrow \infty$ , the current becomes steady and constant,  $\frac{dI}{dt} \rightarrow 0 \implies \mathcal{E}_L \rightarrow 0$ , and  $I = \mathcal{E}/R$ , i.e., the total voltage drop is across the resistor.

When the switch a is closed, we get the equivalent circuit:

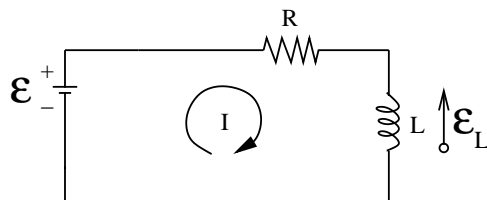

Let's apply the loop rule. We go around the circuit in a clockwise fashion. Then we get voltage drops across the resistor and inductor and a voltage gain from the battery.

$$-IR - \underbrace{L \frac{dI}{dt}}_{\mathcal{E}_L} + \mathcal{E} = 0 \quad (27)$$

or

$$\mathcal{E} = IR + L \frac{dI}{dt}$$

We want to solve this for  $I(t)$  with the initial condition  $I(t = 0) = 0$ , i.e., initially there is no current. The solution is

$$I(t) = \frac{\mathcal{E}}{R} (1 - e^{-Rt/L}) \quad (28)$$

You can check this by plugging  $I(t)$  and  $\frac{dI}{dt} = \frac{\mathcal{E}}{L} e^{-Rt/L}$  into  $IR + L \frac{dI}{dt} = \mathcal{E}$  and seeing that it works. Let's look at

$$I(t) = \frac{\mathcal{E}}{R} (1 - e^{-Rt/L}) \quad (29)$$

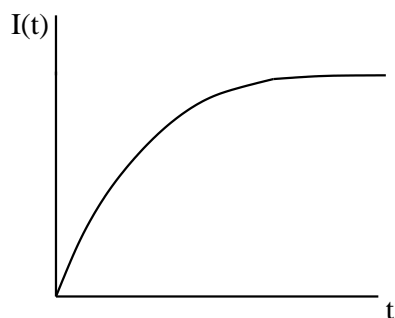

At  $t = 0$ ,  $I = \frac{\mathcal{E}}{R}(1 - 1) = 0$  as desired. Since the voltage drop across the resistor is  $IR$ , there is no voltage drop across the resistor at  $t = 0$ . All the voltage drop is initially across the inductor. As  $t \rightarrow \infty$ ,  $e^{-Rt/L} \rightarrow 0$ , and  $I \rightarrow \frac{\mathcal{E}}{R}$ , i.e., all the voltage drop is across the resistor. Since  $I$  approaches a constant ( $\mathcal{E}/R$ ),  $\frac{dI}{dt} \rightarrow 0$  and no voltage drops across the inductor ( $L \frac{dI}{dt} \rightarrow 0$ ) as  $t \rightarrow \infty$ . Graphically we have:

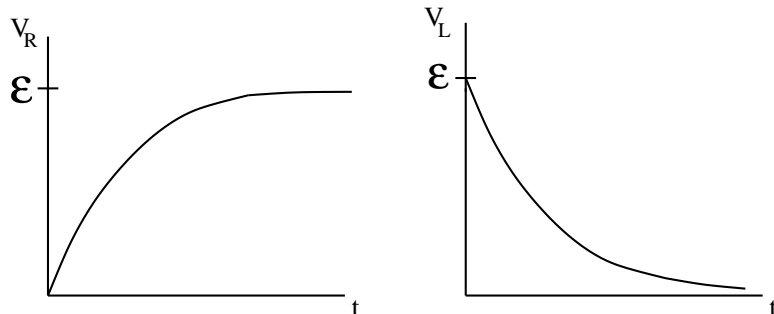

### Time Constant

The time constant in an RL circuit is \_\_\_\_\_.

If we write  $e^{-Rt/L} = e^{-t/\tau_L}$  where  $\tau_L = L/R$ , the inductive time constant  $\tau_L = L/R$  describes the characteristic time over which the current rises to an appreciable value.

(Since the exponent  $-Rt/L$  must be dimensionless,  $L/R$  must have the dimensions of time. You can also check explicitly that  $[L/R] = \text{time}$ .) If we set  $t = \tau_L$ ,

$$I = \frac{\mathcal{E}}{R} (1 - e^{-t/\tau_L}) \Big|_{t=\tau_L} = \frac{\mathcal{E}}{R} (1 - e^{-1}) = 0.63 \frac{\mathcal{E}}{R} \quad (30)$$

i.e., the current has reached 63% of its final value at  $t = \tau_L = L/R$ .

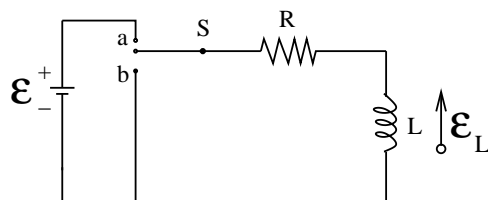

What happens if we remove the battery by closing the switch to  $b$ ? (Close  $b$  before opening  $a$  so the current keeps flowing.) Then our circuit looks like

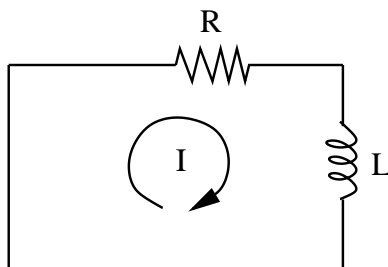

Without a battery the current will decrease with time:  $dI/dt < 0$ . Once again the inductor will resist this change by producing a back emf ( $-LdI/dt$ ). We can write down a differential equation for this circuit by applying the loop rule (or by setting  $\mathcal{E} = 0$  in our previous equation):

$$\begin{aligned} -IR - L \frac{dI}{dt} &= 0 \\ IR + L \frac{dI}{dt} &= 0 \end{aligned}$$

The solution of this equation is

$$I(t) = I_0 e^{-t/\tau_L} \quad (31)$$

where  $\tau_L = L/R$ . At  $t = 0$ ,  $I = I_0 = \mathcal{E}/R$ . As  $t \rightarrow \infty$ ,  $I \rightarrow 0 \implies$  the current is decaying to zero as expected. The characteristic time associated with this decay is  $\tau_L = L/R$ . At  $t = \tau_L$ ,

$$I(t = \tau_L) = I_0 e^{-1} = 0.37 I_0 \quad (32)$$

i.e., the current has decayed to 37% of its original value.

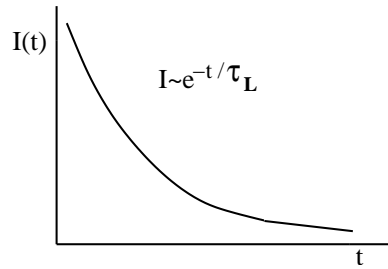

### Adding Inductances

\_\_\_\_\_ inductances in series to get the equivalent inductance.

(Your book forgets to tell you this.) If there are 2 or more inductors in a circuit you add them the same way as you do resistors.

#### In Series

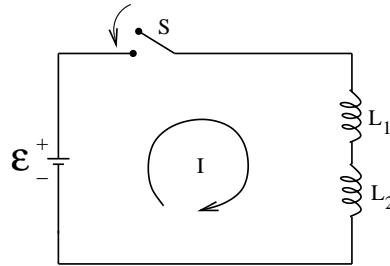

Suppose we shut switch  $S$  in the circuit shown. Then the current  $I$  starts to flow. Since  $I$  increases,  $\frac{dI}{dt} > 0$ . The loop rule gives

$$-L_1 \frac{dI}{dt} - L_2 \frac{dI}{dt} + \mathcal{E} = 0 \quad (33)$$

The sum of the voltage drops across  $L_1$  and  $L_2$  equals the total voltage  $\mathcal{E}$  across them. So we can write

$$\begin{aligned} \mathcal{E} &= L_1 \frac{dI}{dt} + L_2 \frac{dI}{dt} \\ &= (L_1 + L_2) \frac{dI}{dt} \\ &= L_{eq} \frac{dI}{dt} \end{aligned}$$

where

$$L_{eq} = L_1 + L_2 \quad (34)$$

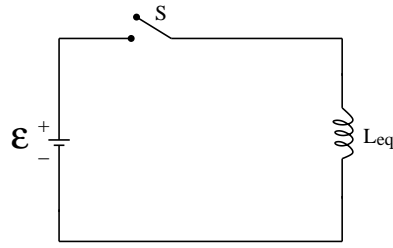

Compare this to  $R_{eq} = R_1 + R_2$  which is the relation for resistors in series. In general, for  $n$  inductors in series,

$$L_{eq} = \sum_{i=1}^n L_i \quad (35)$$

### In Parallel

Add \_\_\_\_\_ inductances in parallel to get the equivalent inverse inductance.

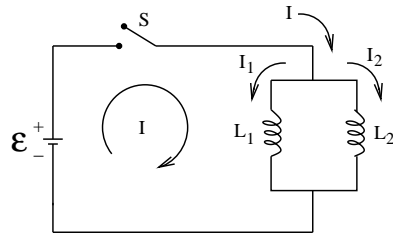

Suppose we shut the switch in a circuit where the inductors are in parallel. Then the voltage drop across each inductor is the same but the current through each is different if  $L_1 \neq L_2$ . Thus

$$\begin{aligned} \mathcal{E} &= L_1 \frac{dI_1}{dt} & \mathcal{E} &= L_2 \frac{dI_2}{dt} \\ \Rightarrow \frac{dI_1}{dt} &= \frac{\mathcal{E}}{L_1} & \frac{dI_2}{dt} &= \frac{\mathcal{E}}{L_2} \end{aligned}$$

Now use the junction rule:

$$\begin{aligned} I &= I_1 + I_2 \\ \frac{dI}{dt} &= \frac{dI_1}{dt} + \frac{dI_2}{dt} \\ &= \frac{\mathcal{E}}{L_1} + \frac{\mathcal{E}}{L_2} \\ &= \mathcal{E} \left( \frac{1}{L_1} + \frac{1}{L_2} \right) \\ &= \mathcal{E} \cdot \frac{1}{L_{eq}} \end{aligned}$$

where

$$\frac{1}{L_{eq}} = \frac{1}{L_1} + \frac{1}{L_2} \quad (36)$$

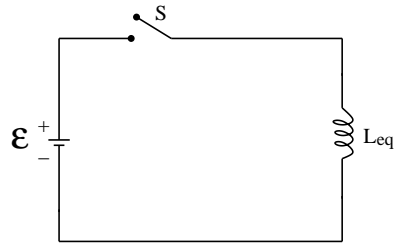

Compare this to  $1/R_{eq} = 1/R_1 + 1/R_2$  for resistors in parallel. In general, for  $n$  inductors in parallel,

$$\frac{1}{L_{eq}} = \sum_{i=1}^n \left( \frac{1}{L_i} \right) \quad (37)$$